

**Flexible monopolar electrodes**

**Item numbers**

HF030-100	HF030-110	HF050-100
HF050-110	HF050-120	HF070-100
HF070-110	HF070-120	HF080-100
HF090-100	HF090-120	HF100-100
HF100-120		

**Device Description**

HF-Monopolar Electrodes are used in combination with suitable working element connected in turn to proper HF-Cable to perform Endoscopic procedures. *Carefully read these instructions before using Rudolf Medical HF-Monopolar Electrodes. Keep them in a safe place for future reference.*

**Intended use**

These products are intended for ablation, cutting, vaporization and coagulation of tissue in the following surgical fields:

- Urology – Resectoscopy
- Gynecology – Hysteroscopy

**Intended User**

The products must be used only in medical facilities by trained and skilled medical personnel. The products must not be used if according to a qualified physician, the general condition of the patient is not adequate or if the endoscopic methods are contraindicated.

**Span-Life**

The electrodes are not to be used more than five (5) different operations.



**Contraindications**

Do not use the devices if one or more below reported conditions is present:

- Acute inflammation of the abdominal area
- Infection of the vagina
- Existing pregnancy
- Patient with pacemaker
- Presence of flammable or explosive substance
- Surgical patients identified as at-risk for Creutzfeldt-Jakob disease (CJD) and related infections should be treated with single-use instruments. Therefore, devices that have been in

use or suspected of use on a patient with CJD after surgery must be disposed according to current national recommendations.

- Improper use can lead to hazardous situations

**Side Effects and Residual Risks**

- When direct or low-frequency current enters the body, electrolysis occurs at the electrode-tissue interface. The chemical effects of electrolysis disappear at higher frequencies
- Direct or low frequency current can depolarize cell membranes and cause neuromuscular excitation
- Electrosection results in more collateral tissue damage compared to scalpel surgery, creating some histologic distortion of surgical margins
- Thermal damage may cause carbonization at the excision margin, vessel thrombosis, and collagen denaturation. Therefore careful evaluation of the advantages and suitability of the intended application is recommended

**Warnings and Precautions**

- Electrodes in combination with standard resectoscopes must only be used with a recovery peak voltage of **max. 2.0 kVp** throughout both standard cutting and coagulation mode
- The electrode tip may remain hot enough to cause burns after current is deactivated
- Inadvertent activation or movement of the electrode outside the field of vision may result in injury to the patient
- Endogenous risk of burns caused by critical current density in the patient's tissue. Probable causes: The patient has inadvertent contact with electrically conductive parts. In the event of direct contact between skin, HF cables and electrodes, capacitive currents may lead to burns
- Exogenous risk of burns caused by inflaming liquids or gases, as well as possible explosions. Probable causes: inflammation of skin cleansers, disinfectants or anaesthetic gases etc.
- Only activate HF current, if the electrode is in your field of view and in contact with tissue otherwise excessive heating of the irrigation medium may result and may cause patient injury.
- Do not bend, deform or tamper with the form of the electrode or the cutting wire

- Ensure that the electrode size corresponds to the size of the inner sheath in use
- To minimize the associated health hazards, specially designed smoke evacuation systems should be used where available and surgical filtration masks donned for all surgical procedures

**Available Models and Combination Products**

**Monopolar HF-Electrodes**

Monopolar HF-electrodes for resectoscopy are to be used in combination with working elements for resectoscopy and resectoscopy sheaths. The corresponding sheaths and electrodes are color coded according to size as follows:

- 19Fr white
- 24Fr yellow
- 27Fr brown/black
- 11Fr green
- 13Fr red

**Bipolar/Saline Electrodes**

Bipolar/saline Electrodes are color coded with a double color code at the distal end

- 19Fr white/blue
- 24Fr yellow/blue
- 27Fr brown/blue

**Cables**

HF cables supplied by Rudolf Medical are compatible with all our working elements and electrodes. The type of HF generator in use determines which size of plug the cable should have at the generator end.



**Generator**

Electrical safety tests were conducted in combination with the HF Surgical Generator ME MB2 by KLS Martin. Comparable HF-Generators can be used in combination with Rudolf Medical's products if it is ensured that maximum power outputs (max. 2.0 kVp) are not exceeded and the connection with suitable cables is ensured. An incorrect combination of products can lead to injury for patients, users or third parts as well as product damage.



**Reprocessing Instructions**

Products are delivered in a Non-Sterile State and must be cleaned, disinfected and sterilized before the first and any other subsequent use

**Warning and Precautions**

Country-specific regulations and laws for cleaning medical products have to be observed.

- For patients with Creutzfeld-Jakob-Disease, CJK-on-spec or its possible variants, Bovine Spongiform Encephalopathy or Transmissible Spongiform Encephalopathy country-specific regulations and laws concerning cleaning of instruments have to be observed
- Do not use metal brushes, sponges, abrasive cleanser, hard or sharp tools to clean electrodes
- Do not bend or deform the electrode or the cutting wire

**Limitation of Reprocessing**

- There are no limitations regarding the number of cleaning and sterilization cycles
- The electrode's durability and lifespan is influenced primarily through wear and tear during application

**Cleaning - Automatic**

**Manual Pre-Cleaning:**

- Rinse electrodes for 5 min under cold water
- Brush electrodes until no debris is detectable with the naked-eye
- Rinse electrodes under cold water

Step	Process Step	Reagents	Time (min)	T (°C)
1	Pre-cleaning	Tap water	2	
2	Drain			
3	Cleaning	Tap water with 0,5% concentration of cleaning agent such as neodisher MediClean (Dr. Weigert, Hamburg)	5	55
4	Drain			
5	Neutralisation	Deionized water	3	
6	Drain			
7	Rinsing	Deionized water	2	
8	Drain			



**Disinfection**

Thermal disinfection shall be performed according to EN ISO 15883-1. This standard uses the term A0 as a measure for the killing of microorganisms in moist-heat processes (hot water)

A0	Time	Temperature
3000	95 sec	95 °C
600	30 sec	93 °C

Do not immerse electrodes in chemical disinfectant. Disinfectant residues can cause adverse effects in function

**Packaging**

HF electrodes should be packed in a sterilization wrap cleared for steam sterilization processes (ISO 11607-1).



As HF electrodes are made of thin metallic components sterilization wrap made out of paper should not be used as the electrodes could perforate the paper seal.

**Sterilization**

Sterilisation of the product with fractional pre-vacuum procedure, in accordance with ISO 17665

- Temperature: 132°C
- Time of exposure: 4 min
- Drying Time: minimum 10 min

**Control and Testing**

The electrodes must be visually examined for cleanliness after every cleaning and disinfection. They have to be macroscopically clean from visual residual and soil.

- If residue, liquids, impurities are visible, repeat cleaning process.
- Ensure that the electrode is faultless prior to each application
- The insulation and HF connector must be intact
- Plastic components should be checked before sterilisation. Electrode must be replaced if plastic components are brittle, cracked or worn

**Recommended Power Setting**

Excessive power setting can lead to significantly higher electrode wear. It is recommended to start with a low power setting gradually increasing until reaching the desired mode:

- Cutting Mode: 120-180 Watt
- Coagulation Mode: Max. 100 Watt

**Mode of Application**

According to the desired mode of action, the following solutions should be used:

- Monopolar Application: e.g. Glycine, Purisole
- Bipolar Application: 0.9% NaCl solution

**Assembling – Disassembling Instructions**

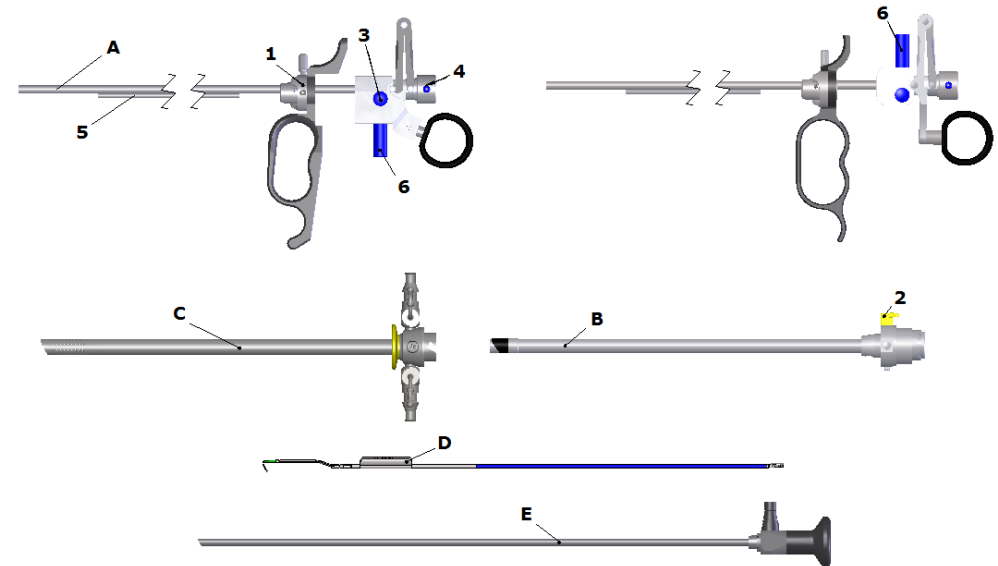

**Assembling**

- Insert HF electrode (D) through the small tube (5) of the working element (A) until the electrode clicks into place in the working element
- Insert working element (A) into inner sheath (B) and lock by turning locking lever (1)
- Insert assembled inner sheath/working element (A+B) into outer sheath (C) and lock by using push button (2)
- Insert endoscope (E) into working element (A) and lock by turning locking lever (4)

**Disassembling**

- Turn the locking mechanism (4), release the endoscope (E) and pull it out of the working element (A)
- Unlock outer sheath by using push-button (2) and remove outer sheath from inner sheath (B)
- Turn locking mechanism to unlock inner sheath (1) and remove from working element (A)
- Unlock HF electrode (D) by using push-button (3) and pull it out of the working element (A)



**Visual and Functional Inspection-Check**

New medical products have to be inspected thoroughly visually and functionally after delivery and prior to each use

- Prior to subsequent use, products should be visually examined for bent, broken or loose parts, damaged insulation, fissures, scratches as well as worn out or cracked parts
- Check that function is as described in the instructions
- Damaged or faulty products should not be used and should be taken out of circulation immediately
- Damaged parts should be immediately replaced by original manufacturer parts



**Electrode Position**

In resting position, the electrode loop have to remain approximately 1.0 mm behind the distal end of the sheath

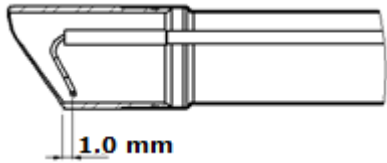

The distance between non-insulated tip of the electrode and the tip of the endoscope has to be at least 2mm

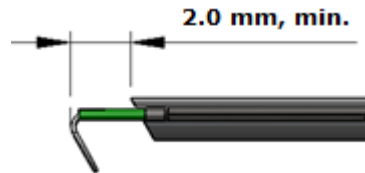

**Never re-bend or tamper with the shape of the loop wire.** It may damage the electrode and lead to hazards for both patient and user

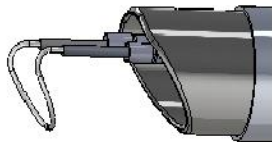

Correct

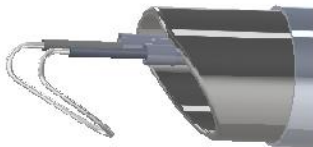

Incorrect

Inadequate distance between HF conductive components and other conductive parts, may lead to unintentional damage of tissue and /or instruments. During application of high frequency to the HF Electrodes, a **distance of at least 8mm** is required from the HF application tip (i.e. loop wire, ball, knife) to the distal end of the endoscope or sheath.

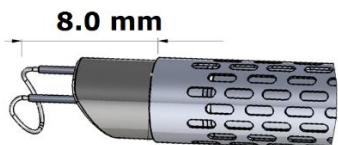

**Storage**

The electrodes must be stored until subsequent use in a suitable sterilization container for steam sterilization according to the standards

The storage room must be dust-free, of low microbiological contamination, dark and free of temperature fluctuations.

**Repairs**

In spite of application in compliance with intended use, medical products are subject to variable wear and tear depending on the intensity of the application. Wear is technically inevitable.

- Do not repair. Service and repairs must be carried out by the manufacturer or by authorized personnel
- Medical products must be cleaned, disinfected and sterilized prior to sending for repair. Soiled or contaminated medical products should not be shipped.

**Warranty**

This product is covered by warranty against production and material defects. In the event of defects under warranty, the product will be repaired, replaced or credited.

All products are designed and manufactured to comply with maximum quality requirements. We refuse any liability for products which, compared to the original product, have been modified, misused or handled or used in an inexperienced way.

**Safety information and explanation of symbols**

	Keep away from sunlight
	Keep dry
	Follow the Instructions for use
<b>REF</b>	Order number
	Non-sterile
	Manufacturer
<b>LOT</b>	Lot number
	CE marking with the identification number of the notified body



RUDOLF Medical GmbH + Co. KG  
Zollerstr. 1, 78567 Fridingen, Germany  
Tel. +49 7463 9956-0  
Fax +49 7463 9956-56  
sales@rudolf-med.com  
www.rudolf-med.com